

26/D-INT. SUPPORT COL.

27/D REACH-IN DR OPN'G

28/D-DAIRY CASE OPN'G

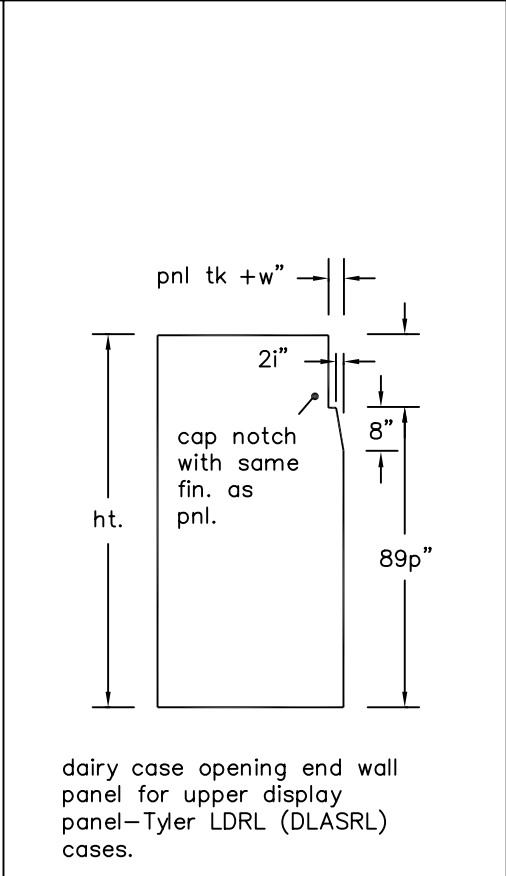
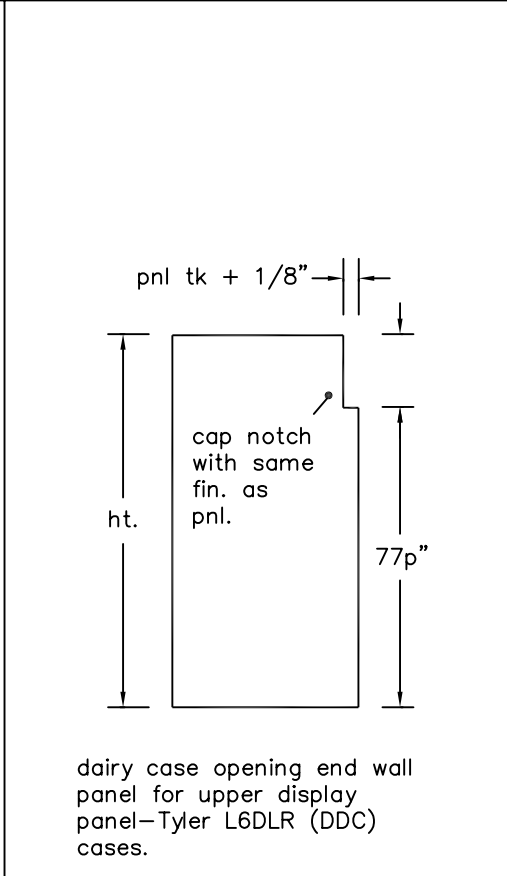
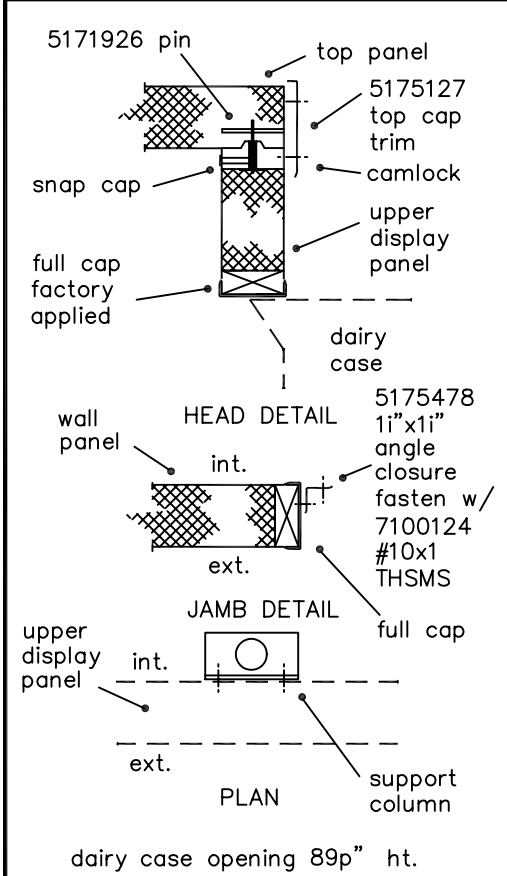

29/D-DAIRY CASE OPN'G

30/D-WALL PANEL NOTCH

31/D-WALL PANEL NOTCH

DESCRIPTION: STANDARD
PANEL CONNECTION
DETAILS

DWG. NO. EML1B-05
SECTION: PANEL DETAILS
DATE: 8-8-01 / 07-08-02
BY: G.E. RANDALL

International Cold Storage
Andover, Kansas
Sales 800-835-0001
Service 800-333-5653
a division of
Carrier Commercial Refrigeration, Inc.

ENGINEERING GUIDE 1B.05